

## N-Channel Enhancement Power MOSFET

### Features

- Low ON Resistance
- Low Reverse transfer capacitances
- 100% Single Pulse avalanche energy Test

### Applications

- Power switching application
- Adapter and charger

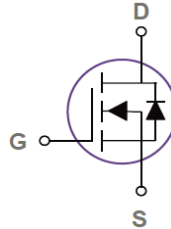

$V_{DSS}$	100V
$I_D(@25^{\circ}C)$	155A
$R_{DS(ON)}$ typ.	4.3m $\Omega$

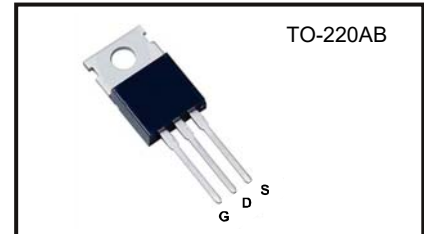

Package Dimensions

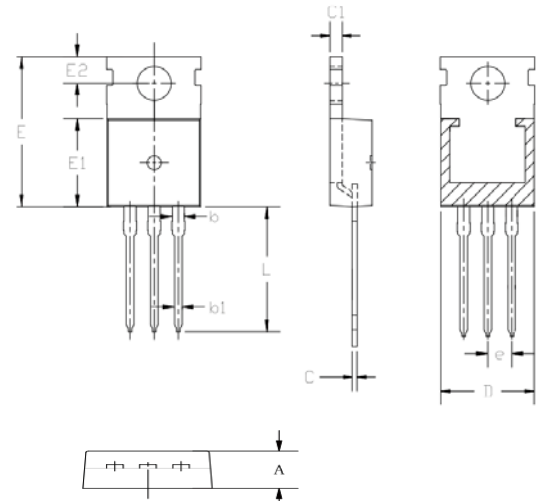

### Absolute Maximum Ratings

( $T_a = 25^{\circ}C$  unless otherwise specified)

Parameter	Symbol	Ratings	Unit
Drain Source Voltage	$V_{DS}$	100	V
Gate Source Voltage @ $T_c = 25^{\circ}C$	$V_{GS}$	$\pm 20$	V
Drain Current Continuous @ $T_c = 25^{\circ}C$ @ $T_c = 100^{\circ}C$	$I_D$	155 98	A
Drain Current Pulsed	$I_{DM}$	620	A
Single Pulse Avalanche Energy	$E_{AS}$	676	mJ
Power Dissipation @ $T_c = 25^{\circ}C$	$P_D$	156	W
Storage Temperature Range	$T_{STG}$	-55 to +150	$^{\circ}C$
Operating Junction Temperature Range	$T_J$	-55 to +150	$^{\circ}C$
Thermal Resistance Junction to Case	$R_{\theta Jc}$	0.8	$^{\circ}C/W$

SYMBOL	MILLIMETER		
	MIN	NOM	MAX
A	4.40	--	4.60
b	1.20	--	1.36
b1	0.70	--	0.90
C	0.48	--	0.53
C1	1.28	--	1.32
D	9.80	10.00	10.20
E	15.20	15.45	15.75
E1	9.00	9.20	9.40
E2	2.60	--	2.90
e	--	2.54	--
L	13.00	--	13.40

**Electrical Characteristics @  $T_J = 25^\circ\text{C}$  (unless otherwise specified)**

Parameter	Symbol	Conditions	Min.	Typ.	Max.	Unit
<b>OFF Characteristics</b>						
Drain-Source Breakdown Voltage	$BV_{DSS}$	$V_{GS} = 0V, I_{DS} = 0.25mA$	100	-	-	V
Drain-to-Source Leakage Current	$I_{DSS}$	$V_{GS} = 0V, V_{DS} = 80V$	-	-	1	$\mu A$
Gated to Source Forward Leakage	$I_{GSS(F)}$	$V_{GS} = +20V$	-	-	100	$\mu A$
Gated to Source Reverse Leakage	$I_{GSS(R)}$	$V_{GS} = 20V$	-	-	-100	nA
<b>ON Characteristics</b>						
Gate Threshold Voltage	$V_{GS(th)}$	$V_{DS} = V_{GS}, I_D = 0.25mA$	2.0	3.2	4.0	V
Drain-Source On-State Resistance	$R_{DS(on)}$	$V_{GS} = 10V, I_D = 50A$	-	4.3	5.1	m $\Omega$
Transconductance	$g_{fs}$	$V_{DS} = 10V, I_D = 10A$	-	35.7	-	S
Gate Resistance	$R_g$	$V_{DS} = V_{GS} = 0V, f = 1MHz$	-	2	-	$\Omega$
<b>Dynamic Characteristics</b>						
Input Capacitance	$C_{iss}$	$V_{DS} = 50V$	-	3153	-	pF
Output Capacitance	$C_{oss}$	$V_{GS} = 0V$	-	842	-	
Reverse Transfer Capacitance	$C_{rss}$	Freq. = 1.0MHz	-	14	-	
<b>Switching Characteristics</b>						
Turn-On Delay Time	$t_{d(on)}$	$V_{DS} = 50V$ $I_D = 20A$ $R_G = 3\Omega$ $V_{GS} = 10V$	-	13.5	-	ns
Rise Time	$t_r$		-	15.7	-	
Turn-Off Delay Time	$t_{d(off)}$		-	28	-	
Fall Time	$t_f$		-	13.8	-	
Total Gate Charge	$Q_g$	$V_{DS} = 50V$	-	51.5	-	nC
Gate to Source Charge	$Q_{gs}$	$V_{GS} = 10V$	-	14.4	-	
Gate to Drain Charge	$Q_{gd}$	$I_D = 20A$	-	14.5	-	
<b>Body Diode Characteristics</b>						
Continuous source-drain diode current	$I_{SD}$		-	-	155	A
Diode Forward Voltage	$V_{SD}$	$V_{GS} = 0V, I_S = 50A$	-	0.9	1.2	V
Reverse Recovery Time	$T_{rr}$	$I_{SD} = 20A$	-	54.8	-	ns
Reverse Recovery Charge	$Q_{rr}$	$di/dt = 100A/\mu s$	-	61.6	-	nC

\*Pulse Test: Pulse Width  $\leq 300\mu s$ , Duty Cycle  $\leq 2\%$

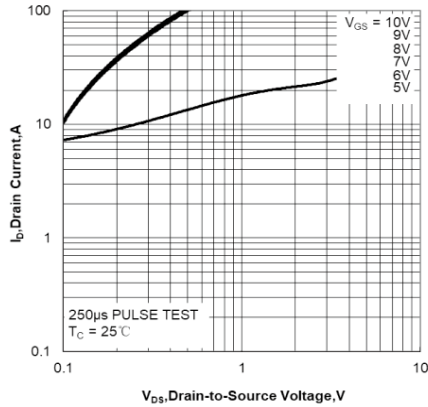
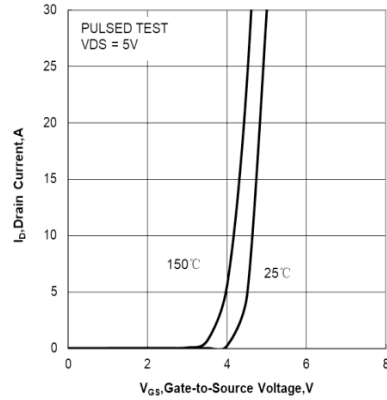
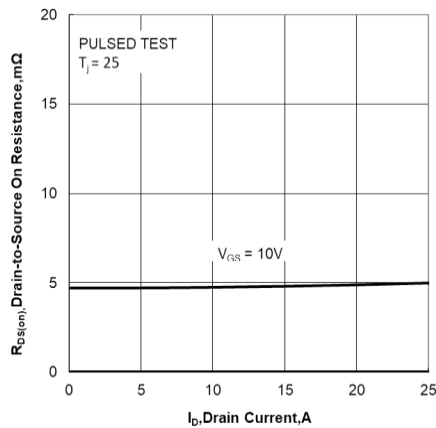
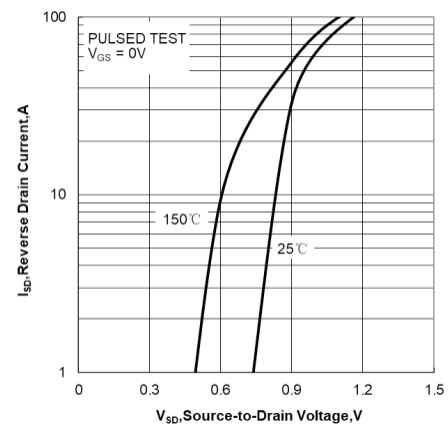
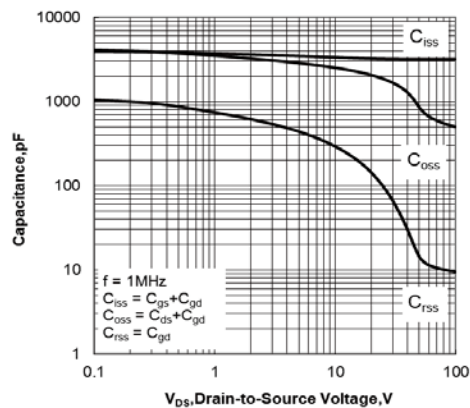
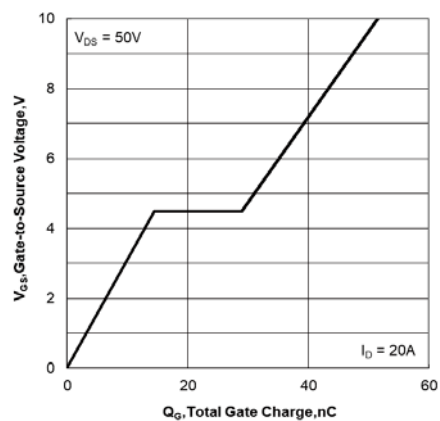
**Typical Performance Characteristics**
**Figure 1. Output Characteristics**

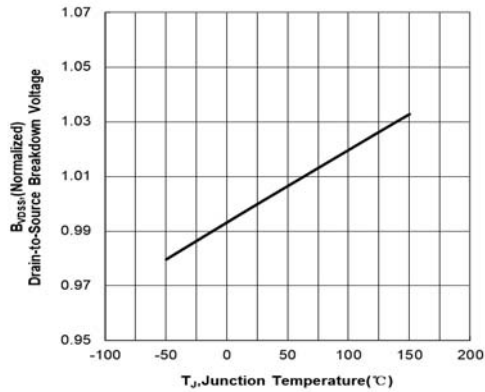
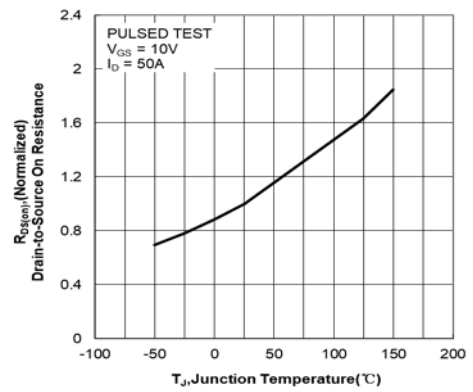
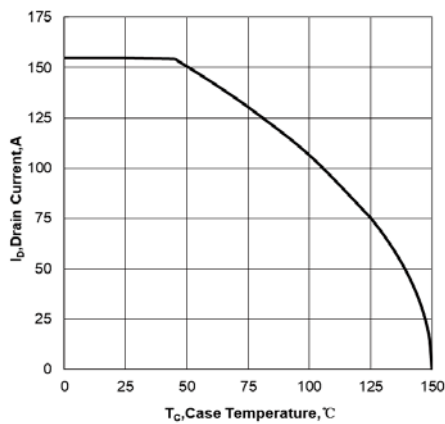
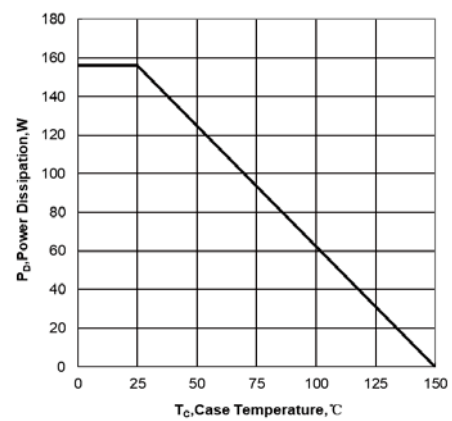
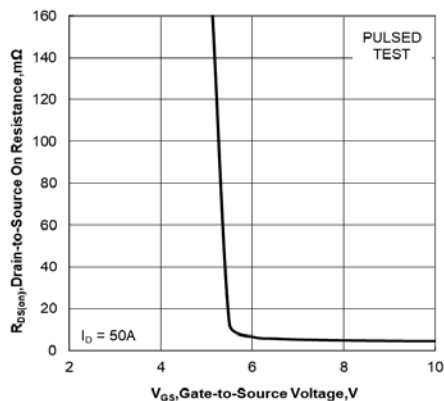
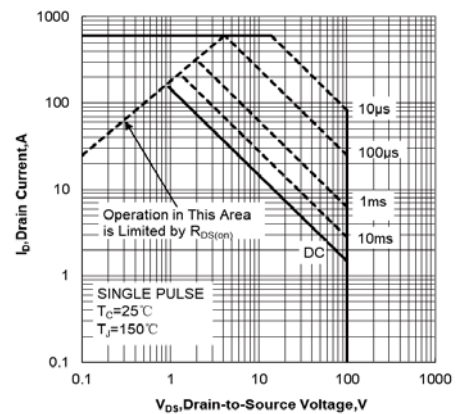
**Figure 2. Transfer Characteristics**

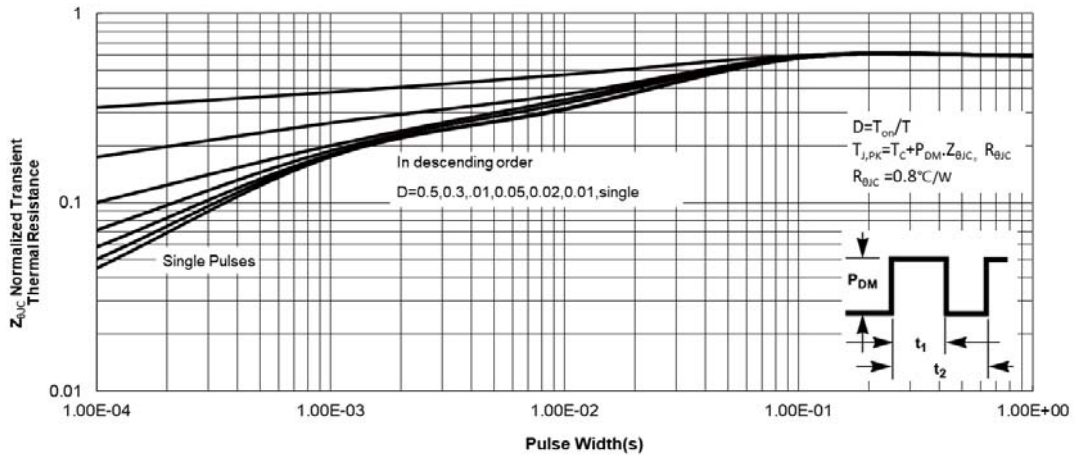
**Figure 3. Drain-to-Source On Resistance vs Drain Current**

**Figure 4. Body Diode Forward Voltage vs Source Current and Temperature**

**Figure 5. Capacitance Characteristics**

**Figure 6. Gate Charge Characteristics**

**Typical Performance Characteristics**
**Figure 7. Normalized Breakdown Voltage vs Junction Temperature**

**Figure 8. Normalized On Resistance vs Junction Temperature**

**Figure 9. Maximum Continuous Drain Current vs Case Temperature**

**Figure 10. Maximum Power Dissipation vs Case Temperature**

**Figure 11. Drain-to-Source On Resistance vs Gate Voltage and Drain Current**

**Figure 12. Maximum Safe Operating Area**

**Typical Performance Characteristics**
**Figure 13. Maximum Effective Transient Thermal Impedance, Junction-to-Case**

## **Disclaimer**

DACO Semiconductor reserves the right to make modifications, enhancements, improvements, corrections, or other changes to this document and any product described herein without prior notice. For the most up-to-date version, please visit our website.

DACO Semiconductor makes no warranty, representation, or guarantee regarding the suitability of its products for any particular purpose, nor does DACO Semiconductor assume any liability arising out of the application or use of any product or circuit, and specifically disclaims any liability, including without limitation special, consequential or incidental damages.

Purchasers are responsible for its products and applications using DACO Semiconductor products, including compliance with all laws, regulations, and safety requirements or standards, regardless of any support or application information provided by DACO Semiconductor. "Typical" parameters that may be provided in DACO Semiconductor datasheets and/or specifications can and do vary in different applications and actual performance may vary over time. All operating parameters, including "Typical" must be validated for each customer application by the customer's technical experts.

DACO Semiconductor products are not designed, authorized, or warranted to be suitable for use in life support, life-critical or safety-critical systems, or equipment, nor in applications where failure or malfunction of DACO Semiconductor's product can reasonably be expected to result in personal injury, death or severe property or environmental damage. DACO Semiconductor accepts no liability for the inclusion and/or use of DACO Semiconductor's products in such equipment or applications and therefore such inclusion and/or use is at the customer's own risk.

Purchasers who buy or use DACO Semiconductor products for any unintended or unauthorized applications are required to indemnify and absolve DACO Semiconductor, its suppliers, and distributors from any claims, costs, damages, expenses, and reasonable attorney fees arising out of, directly or indirectly, any claim of personal injury or death associated with such unintended or unauthorized use, even if such claim alleges that DACO Semiconductor was negligent regarding the design or manufacture of the part.

No part of this publication may be reproduced or transmitted in any form or by any means, electronic or mechanical, including photocopying and recording, or by any information storage and retrieval system, or otherwise, without the prior written permission of DACO Semiconductor Co., Ltd.