

### 3.0A STANDARD DIODE

#### Features

- Glass Passivated Die Construction
- Low Forward Voltage Drop
- High Current Capability
- High Reliability
- High Surge Current Capability

Glass passivation junction chip inside.

#### Mechanical Data

- Case: DO-201AD, Molded Plastic
- Terminals: Plated Leads Solderable per MIL-STD-202, Method 208
- Polarity: Cathode Band
- Weight: 1.2 grams (approx.)
- Mounting Position: Any
- Marking: Type Number
- **Lead Free: For RoHS / Lead Free Version**

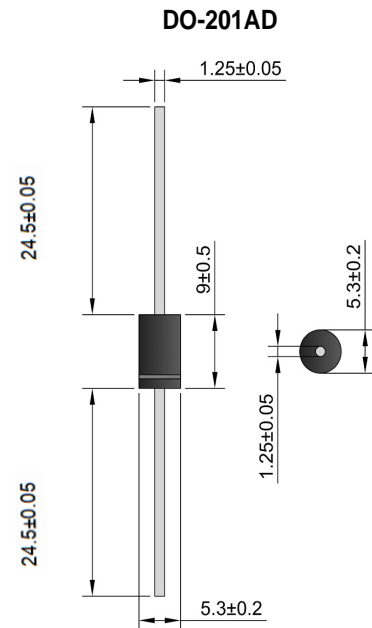

#### Maximum Ratings and Electrical Characteristics

@ $T_A=25^{\circ}\text{C}$  unless otherwise specified Single Phase, half wave, 60Hz, resistive or inductive load.

For capacitive load, derate current by 20%.

Characteristic	Symbol	1N 5400G	1N 5401G	1N 5402G	1N 5404G	1N 5406G	1N 5407G	1N 5408G	Unit
Peak Repetitive Reverse Voltage	$V_{RRM}$	50	100	200	400	600	800	1000	V
Working Peak Reverse Voltage	$V_{RWM}$								
DC Blocking Voltage	$V_R$								
RMS Reverse Voltage	$V_{R(RMS)}$	35	70	140	280	420	560	700	V
Average Rectified Output Current (Note 1) @ $T_A = 75^{\circ}\text{C}$	$I_O$	3.0							A
Non-Repetitive Peak Forward Surge Current 8.3ms Single Half Sine-Wave Superimposed on Rated Load (JEDEC Method)	$I_{FSM}$	120							A
Forward Voltage @ $I_F = 3.0\text{A}$	$V_{FM}$	1.0							V
Peak Reverse Current @ $T_A = 25^{\circ}\text{C}$ At Rated DC Blocking Voltage @ $T_A = 100^{\circ}\text{C}$	$I_{RM}$	5.0 100							$\mu\text{A}$
Typical Junction Capacitance (Note 2)	$C_J$	30							pF
Typical Thermal Resistance Junction to Ambient (Note 1)	$R_{JA}$	20							$^{\circ}\text{C}/\text{W}$
Operating Temperature Range	$T_J$	-65 to +125							$^{\circ}\text{C}$
Storage Temperature Range	$T_{STG}$	-65 to +150							$^{\circ}\text{C}$

Note: 1. Leads maintained at ambient temperature at a distance of 9.5mm from the case.

2. Measured at 1.0 MHz and Applied Reverse Voltage of 4.0V D.C.

Fig. 1 Forward Current Derating Curve

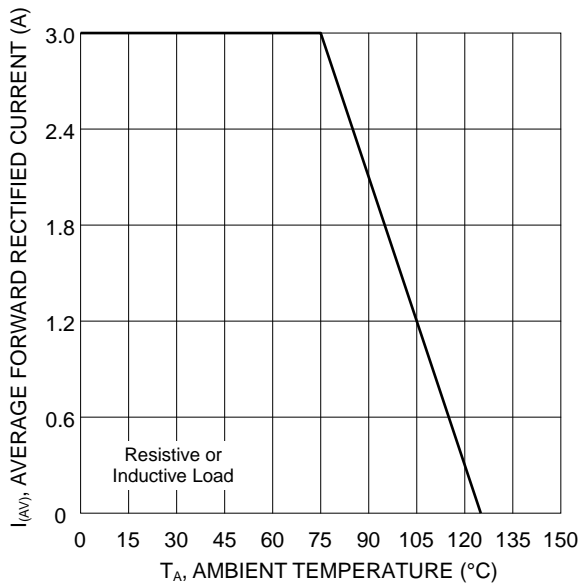

Fig. 2 Typical Forward Characteristics

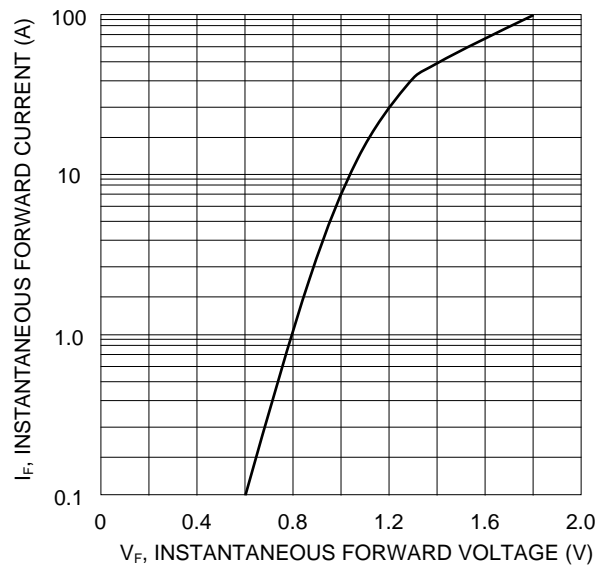

Fig. 3 Forward Surge Current Derating Curve

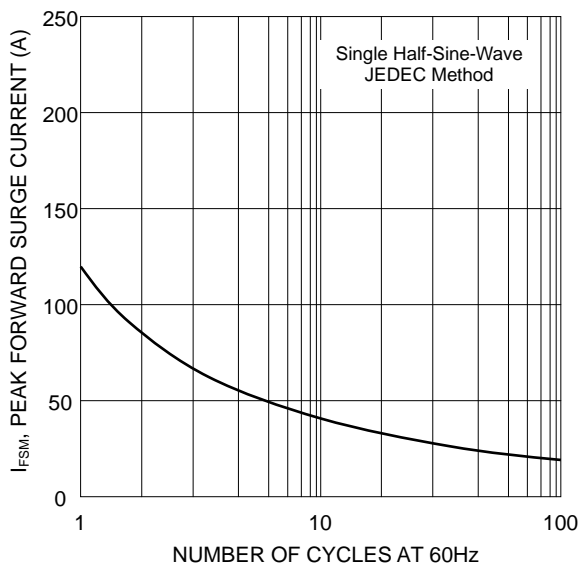

Fig. 4 Typical Reverse Characteristics

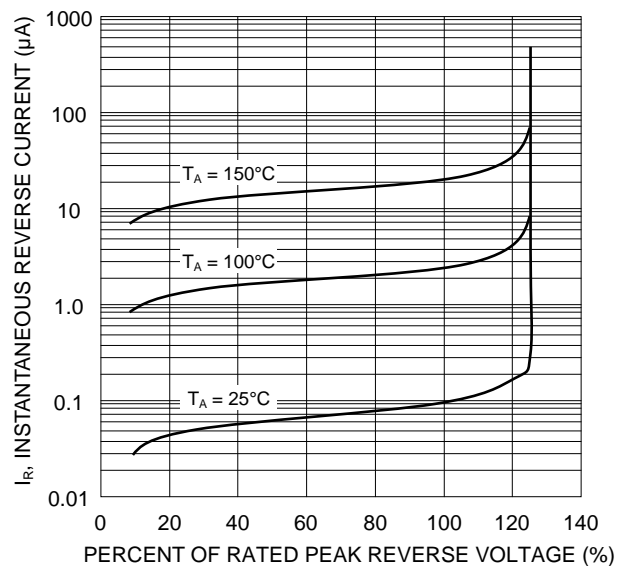
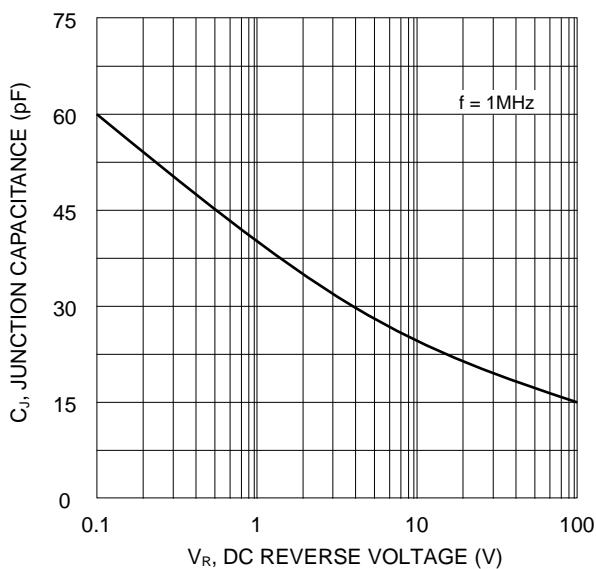
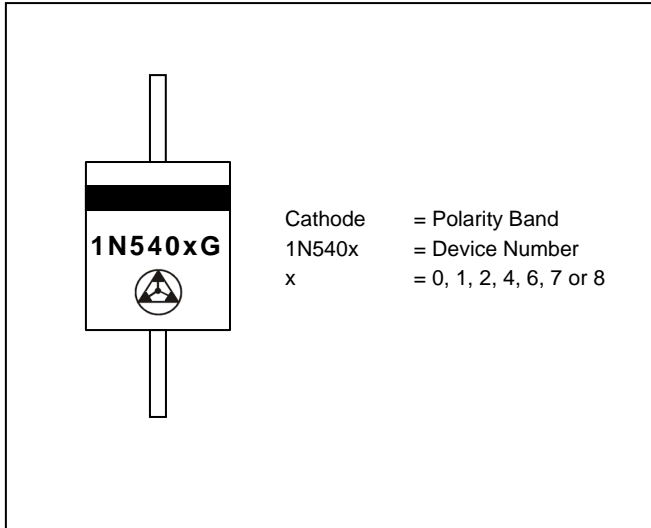
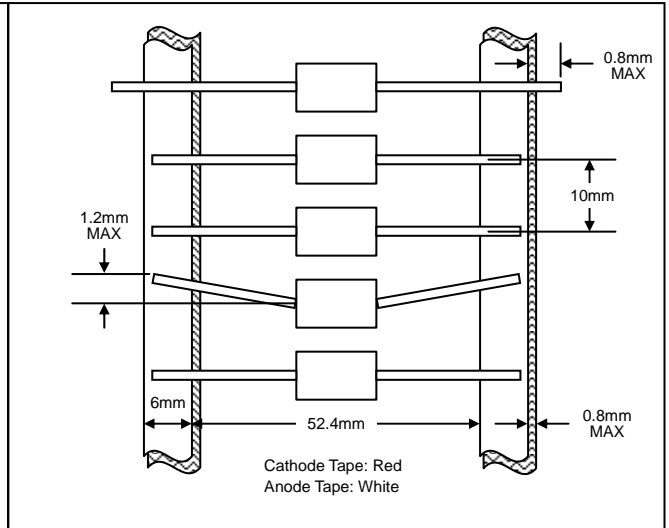
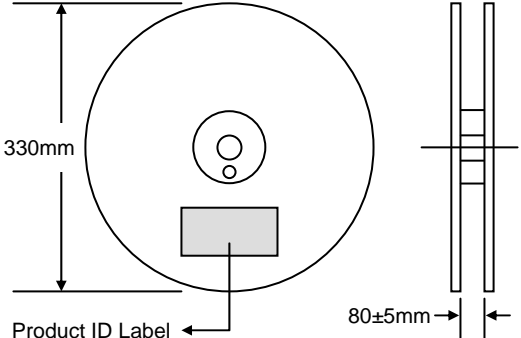

Fig. 5 Typical Junction Capacitance



**MARKING INFORMATION**

**TAPING SPECIFICATIONS**

**PACKAGING INFORMATION**

**TAPE & REEL**

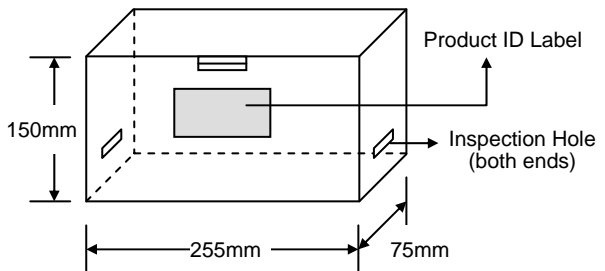

330mm  
 Product ID Label  
 80±5mm

**TAPE & BOX**



150mm  
 Product ID Label  
 Inspection Hole (both ends)  
 255mm  
 75mm

**BULK**

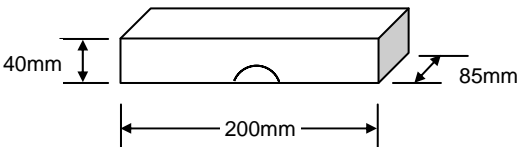

40mm  
 200mm  
 85mm

Packaging	Reel Diameter / Box Size (mm)	Quantity (PCS)	Carton Size (mm)	Quantity (PCS)	Approx. Gross Weight (KG)
<b>TAPE &amp; REEL</b>	330	1,200	370 x 370 x 420	6,000	10.0
<b>TAPE &amp; BOX</b>	255 x 75 x 150	1,200	400 x 273 x 415	12,000	17.0
<b>BULK</b>	200 x 85 x 40	500	459 x 214 x 256	12,500	16.0

## Disclaimer

DACO Semiconductor reserves the right to make modifications, enhancements, improvements, corrections, or other changes to this document and any product described herein without prior notice. For the most up-to-date version, please visit our website.

DACO Semiconductor makes no warranty, representation, or guarantee regarding the suitability of its products for any particular purpose, nor does DACO Semiconductor assume any liability arising out of the application or use of any product or circuit, and specifically disclaims any liability, including without limitation special, consequential or incidental damages.

Purchasers are responsible for its products and applications using DACO Semiconductor products, including compliance with all laws, regulations, and safety requirements or standards, regardless of any support or application information provided by DACO Semiconductor. "Typical" parameters that may be provided in DACO Semiconductor datasheets and/or specifications can and do vary in different applications and actual performance may vary over time. All operating parameters, including "Typical" must be validated for each customer application by the customer's technical experts.

DACO Semiconductor products are not designed, authorized, or warranted to be suitable for use in life support, life-critical or safety-critical systems, or equipment, nor in applications where failure or malfunction of DACO Semiconductor's product can reasonably be expected to result in personal injury, death or severe property or environmental damage. DACO Semiconductor accepts no liability for the inclusion and/or use of DACO Semiconductor's products in such equipment or applications and therefore such inclusion and/or use is at the customer's own risk.

Purchasers who buy or use DACO Semiconductor products for any unintended or unauthorized applications are required to indemnify and absolve DACO Semiconductor, its suppliers, and distributors from any claims, costs, damages, expenses, and reasonable attorney fees arising out of, directly or indirectly, any claim of personal injury or death associated with such unintended or unauthorized use, even if such claim alleges that DACO Semiconductor was negligent regarding the design or manufacture of the part.

No part of this publication may be reproduced or transmitted in any form or by any means, electronic or mechanical, including photocopying and recording, or by any information storage and retrieval system, or otherwise, without the prior written permission of DACO Semiconductor Co., Ltd.